

# scalmax

advanced autogas technology



**LPG CNG LNG**  
product catalogue



# Ecological autogas systems

## Contents

3	About Scalmax	○
4-6	Autogas installation elements	○
6-9	LPG / CNG / LNG injector and injector accessories	○
10-13	Sequential gas injection systems	○
14-15	Autogas Scalmax systems component	○
16	Sequential gas injection for gasoline engines - Minikit	○
17-20	Diesel Dual Fuel Systems	○
21	Diesel Dual Fuel - Minikit	○
22	Diesel Dual Fuel + Telemetry	○
23	CNG/LNG Reducer with Innovative Electric Heating System - Professional Solution for Engines up to 300 kW.	○



# scalmax

advanced autogas technology

SCALMAX has been operating in the autogas industry since 2004. At 2004 we developed 8 cylinder sequential injection system that was working in real time. In the autogas market, we are known as providers of comprehensive solutions for the conversion of engines to LPG, CNG and LNG. Our many years of experience in manufacturing of autogas controllers changed our views on the needs of drivers and car repair shops. We were the first in Poland to create an innovative controller for Diesel Dual Fuel systems at 2009. In our own projects we use the best solutions based on durable components that are at highest technology level.

At SCALMAX, we work according the ISO 9001: 2015 Quality Management System for the production and design of automotive components.



SCALMAX has a modern machine park in the industry 4.0 standard, these are modern CNC machines, the latest global solutions for plastic injection, automatic component assembly systems. We have a research and development department that constantly improves and develops new products dedicated to the LPG, CNG and LNG market. We also design electronics, automation and connect embedded computer systems for external companies.

# scalmax

advanced autogas technology

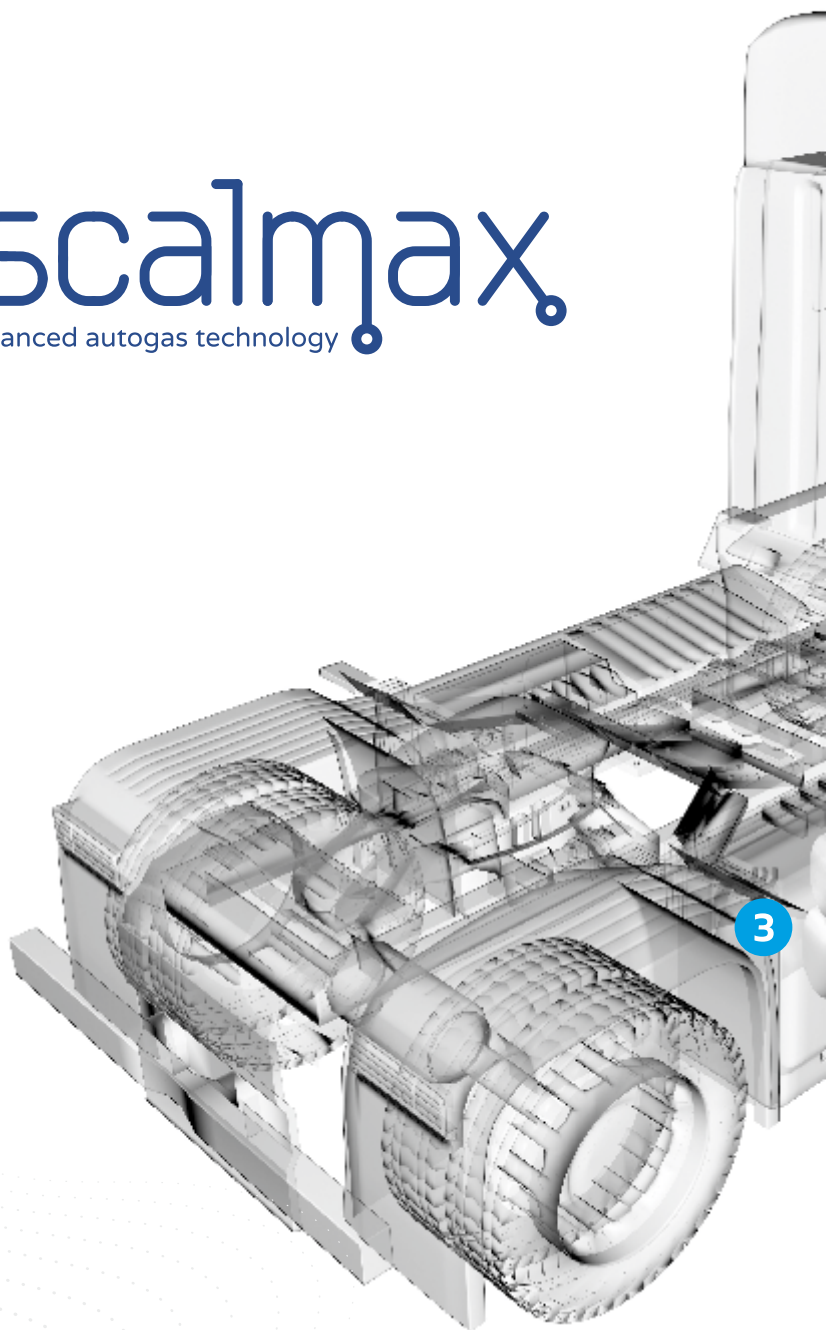

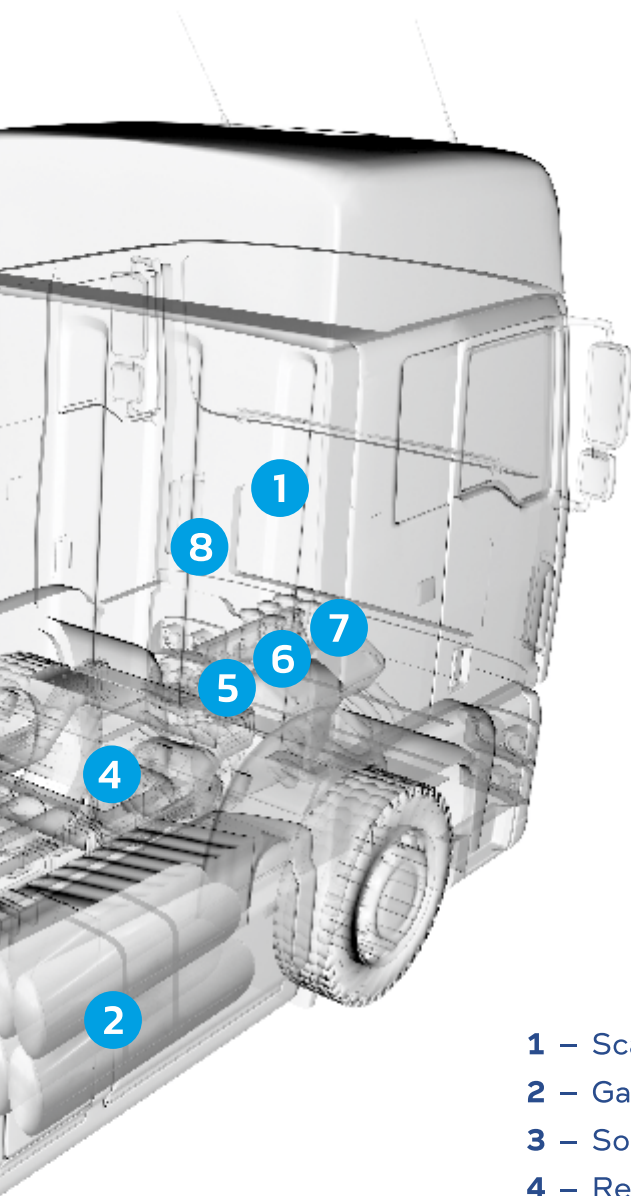

- 1** – Scalmax autogas controller
- 2** – Gas tank
- 3** – Solenoid valve
- 4** – Reducer
- 5** – Filter
- 6** – MAP sensor Scalmax
- 7** – Injectors Scalmax
- 8** – Scalmax fuel switch

# SCALMAX LPG/CNG/LNG INJECTORS



# RAPTOR

*SPEED & PRECISION*



The RAPTOR injector is a high-precision, top-feed gas injector, made of high quality resistant stainless steel for corrosion, aging, adapted to work in the environment aggressive (LPG, CNG, LNG), and variable working conditions in engine compartment (from -40 to +125 [°C]) It is characterized by high magnetic permeability, low hysteresis and saturation of the electromagnetic core, which have a decisive impact on the speed and repeatability of the injector. An innovative solution, a specially designed nozzle supports the mixing of the gas with air. The system is protected by a patent application. The polymeric materials used for the sliding coatings, and the fluoropolymer sealing coatings ensure life cycle 1 000 000 000 and stability of parameters, that meet the requirements of modern norms for combustion engines exhaust gases.

## Technical parameters

- operation with LPG / CNG / LNG
- opening time: 1.85 [ms] +/- 0.05 [ms]
- closing time: 0.9 [ms] +/- 0.1 [ms]
- maximum flow (without a nozzle) - 120 [l/min] (40- 50 km per cil.)
- coil resistance 1.9 [Ohm]
- supply voltage: 10-16 [V] DC
- maximum opening current: 4.5 [A] for 2.8 [ms]
- maximum holding current: 1.5 [A]
- temperature operation: -40 to +125 [°C]
- working pressure: 0-4.0 [Bar]
- FKM sealing elements
- input filter 120 [mesh]
- gas inlet D = 6 [mm]
- gas outlet D = 6 [mm]
- calibration nozzles int. size D = 1.5 [mm], ( can be drilled)
- warranty 2 years or 100,000 [km],
- durability 1,000,000,000 cycles (10<sup>9</sup>)
- ECE, R67, R110 approval

**scalmax**  
advanced autogas technology

## SCALMAX LPG/CNG/LNG INJECTORS



# SCALMAX LPG/CNG/LNG INJECTORS



**R A P T O R**  
*SPEED & PRECISION*

## Injector accessories

---

### Complete range of adapters:

1. Distributor rail (x2 cylinders, x3 cylinders, x4 cylinders), 12 mm input, 6 mm output
2. Injector rail (x2 cylinders, x3 cylinders, x4 cylinders), 12 mm input
3. Longitudinal adapter (for installation with the manifold rail), input 6 mm
4. Angled and straight adapter for the assembly of the injectors as close to the manifold as possible, input 12mm



**scalmx**  
advanced autogas technology

# SCALMAX LPG/CNG/LNG INJECTORS



		hp/cil	15	20	30	40	45	50
Pressure	LPG	1.0 Bar	1,8 - 1,9	1,9 - 2,1	2,3 - 2,5	2,8 - 3,0		
		1,2 Bar	1,7 - 1,8	1,8 - 2,0	2,2 - 2,4	2,6 - 2,8	2,8 - 3,0	
		1,4 Bar	1,5 - 1,7	1,7 - 1,9	2,0 - 2,2	2,5 - 2,7	2,7 - 2,9	2,8 - 3,0
CNG	1,8 Bar	1,8 - 1,9	1,9 - 2,1	2,3 - 2,5	2,8 - 3,0			
	2.0 Bar	1,7 - 1,8	1,8 - 2,0	2,2 - 2,4	2,6 - 2,8	2,8 - 3,0		
	2,2 Bar	1,5-1,7	1,7 - 1,9	2,0 - 2,2	2,5 - 2,7	2,7 - 2,9	2,8 - 3,0	

(Diameters of calibration nozzles in mm)

# SEQUENTIAL GAS INJECTION SYSTEMS



**B I S O N**  
STRENGTH & QUALITY

**BISON OBD** – 4 cylinders sequential ECU, new SCALMAX platform for gasoline engines. Electronic Control Unit was designed for conversion 4 cylinder, Euro 6 engines (modern engines with multipoint injection system - indirect injection).

Compact construction in a modern design, at the highest technological level. SCALMAX has made every effort to ensure that the controller uses the most modern and reliable components for highest quality to autogas automotive market. This is why processor of ECU can operate in military range of temperatures: -40 [°C] up to +150 [°C]. It is a new economical platform for autogas controllers ensuring the highest quality in the conversion of passenger cars to LPG / CNG / LNG. Easy calibration of the gas system – just set few basic parameters and the rest will do Automatic tuning with Fuzzy Logic function. You do not have to be highly experienced in autogas systems to set BISON perfect for the engine.

## Technical parameters

- DSP processor speed 380 [Mhz]
- 12 [V] DC system
- Composite Housing
- ECU works without cycle delay in real time
- time sampling frequency 0.0002 [ms] (0.2 [µs])
- OBD CAN option
- Start / Stop function
- Hybrid function
- VALVETRONIC engine support
- VALVEMATIC engine support
- VAG function support
- Mazda injection support
- Dynamic correction maps
- "Fuel overlapping" function
- Hybrid emulator
- Automatic tuning with Fuzzy Logic function
- Extreme operating temperature range from -40 [°C] to +150 [°C] ( -40 [°F] to 302 [°F] )

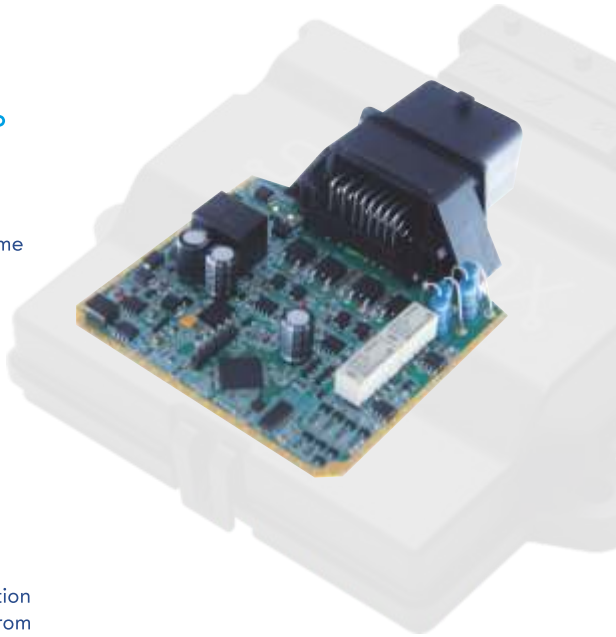

## SEQUENTIAL GAS INJECTION SYSTEMS

These are just some of the features from the wide range of possibilities of the new BISON Autogas controller based on a modern 16-bit DSP microcontroller (digital signal processing). The processor offers unprecedented possibilities in the processing of engine signals connected by the installer, both digital (e.g. injection times) and analog (gas pressure, manifold pressure, gas temperature). This significantly increases the sampling frequency of the injection time signals: below the limit of 1 [us] (sampling time 0.2 [us]) and accelerates the conversion of corrections from physical values in the controller. The operating speeds of the ECU core translate into more accurate dosing of the gas mixture by the injectors. The combination of BISON with precise LPG / CNG / LNG injectors Scalmax allows you to meet the Euro 6 exhaust gas emission standard. Bison has a built-in algorithm of constant gas mixture control based on fuzzy logic, which allows the installer to reduce the time needed to put the gas installation to a minimum. The entire procedure is limited to selecting nozzles, setting basic parameters and adjusting the idle speed. Ergonomic housing, quick assembly are additional advantages.



**sold in a package with accessories and a wiring harness**



# SEQUENTIAL GAS INJECTION SYSTEMS

## Scalmax SM030 OBD

**SM030 OBD** controller has been designed with minor engines (up to 4 cylinders) in mind. It offers a wide range of functions allowing users to set gas injections according to their needs. The fact that it can integrate with car CAN system makes it an optimal choice for newer cars with a port injection. The system can be easily installed and operated on a daily basis.



Up to  
**4** cylinders



### DSP Digital Signal Processor

DSP Digital Signal Processor available in the version designed for car electronics with high resistance to environmental conditions (-40° to +125° [C]).



### SSA Scalmax Smart Adaptation

Scalmax auto-adaptation system has been developing for many years. At present it is a smart algorithm assuring an optimal operation in any environmental conditions.



### HDM Height Density Mapping

Thanks to more precise liquid fuel parameters mapping, High Density Maps assure more dynamic and smooth LPG-powered engine operation.



### OBD On-Board Diagnostics

Diagnostics and error deleting options. Adaptation to petrol ECU corrections allows configuration of adaptation to long- or short-term correction and both corrections at a time.

ECE R67, R110, R10 approval

**sold in a package with accessories and a wiring harness**

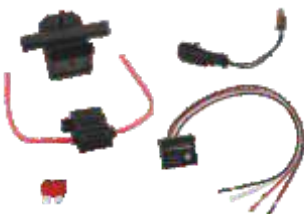

# SEQUENTIAL GAS INJECTION SYSTEMS

## Scalmax SM010.3 OBD

**SM010.3 OBD controller** has been designed to control larger engines in versions with up to 6 and 8 cylinders. It has a complex current and voltage filtration system necessary for cars with larger engines. The system ensures a strong and economical engine.



Up to  
**8** cylinders



### DSP Digital Signal Processor

DSP Digital Signal Processor available in the version designed for car electronics with high resistance to environmental conditions (-40° to +125° [C]).



### SSA Scalmax Smart Adaptation

Scalmax auto-adaptation system has been developing for many years. At present it is a smart algorithm assuring an optimal operation in any environmental conditions.



### HDM Height Density Mapping

Thanks to more precise liquid fuel parameters mapping, High Density Maps assure more dynamic and smooth LPG-powered engine operation.



### OBD On-Board Diagnostics

Diagnostics and error deleting options. Adaptation to petrol ECU corrections allows configuration of adaptation to long- or short-term correction and both corrections at a time.

ECE R67, R110, R10 approval

**sold in a package with accessories and a wiring harness**

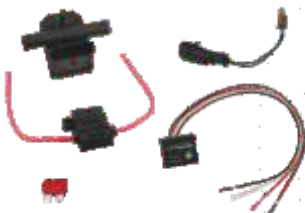

# SYSTEM COMPONENTS

## Scalmax SM061 Microprocessor Switch

A compact, lightweight, switch that signals the operation of the gas installation, both LPG/CNG/LNG as well as Dual Fuel Systems, e.g. gas + diesel. It signals both the operating status and the level of refueled gas.

### Technical parameters

- Supply voltage 5 [V] DC +/- 5%
- Working temperature -40° to + 85 [°C] (the device is mounted in the vehicle cabin)
- Built-in electro-mechanical speaker
- Compact composite housing
- Built-in micro switch
- Gas level indication on 5 LEDs
- LED diode operation status indication
- Cable length 200 mm
- Standard 4 connection wires (black - ground, red - [V] DC, brown - data transmission, white – signal switch)
- Optional 3 connection cables (black - ground, red - [V] DC, brown-white - data transmission connected with switch signal)



## Scalmax SM045 USB interface

The universal tough design makes the interface the best on the market. In the basic version it is a galvanically isolated interface, which means optical control signals, i.e. the safest on market. In case the cable is damaged (cut or broken), it is enough to replace the cheap USB extension cable. The diagnostic interface also works with other types of gas installations on the market.

### Technical parameters

- Supply voltage 12 [V] DC (10 - 16 [V] DC)
- Working temperature -40° to + 85 [°C]
- The interface is galvanically isolated (gas installation-computer) it means that only optical signals combine 2-way transmission
- Can work in FULL DUPLEX mode with a maximum speed of 115 [kBaud]
- Composite housing
- Separate signaling LEDs inside the housing sending and receiving data
- 5 [m] long USB 2.0 A / B cable included.
- Optionally there is an interface without galvanic isolation computer-powered to operate low-end devices.
- Possibility to configure the interface.



# SYSTEM COMPONENTS

## Scalmax SM033 MAP-Sensor

---

The pressure and temperature sensor of the gas and the intake manifold has high accuracy, compact design and enormous resistance to dirt contained in LPG / CNG / LNG gas.

- Supply voltage 5 [V] DC +/- 5%
- Optional 12 VDC (10 - 16 [V] DC) version
- 5 Pins:
  - PIN 1 - GND (ground)
  - PIN 2 - Gas pressure 0-4 [Bar] (Pres)
  - PIN 3 - Collector pressure 0-4 [Bar] (Vac)
  - PIN 4 - Gas temperature -40° to + 120 [°C] (TG)
  - PIN 5 - Supply voltage 5 [V] DC (VDC), optional 12 [V] DC
- TUV ECE R67, R110 approval
- Gas pressure measurement based on Freescale sensors, gas flow temperature measurement based on an NTC 4k7 thermistor
- Composite housing



## Scalmax SM014 EGT sensor

---

Exhaust gas temperature sensor made with CNC technology and laser welding with accuracy reaching up to 0.01 [mm] , can be successfully used in gas installations as well as in motorsport and as a sensor in jet engines.

### Technical parameters

---

- made of the highest quality stainless steel and NiCr-Ni alloy, laser welded for sealing sensor
- Working temperature range: -200 [°C] to +1000 [°C]
- Sealed on stainless steel (sealing sleeve included)
- Connecting cables: white, green
- Stainless steel spring to prevent damage to the cables when working in conditions increased vibrations
- Designed to work in the exhaust system internal combustion engine



# SEQUENTIAL GAS INJECTION FOR GASOLINE ENGINES - MINIKIT

To provide end customers with a proven product at the right price, we have prepared kits. The Scalmax assembly kit consists of an LPG / CNG controller equipped with a harness and a kit assembly (mapsensor, reducer temperature sensor, switch). The MINIKIT kit also includes gas level indicator (or pressure gauge), LPG or CNG reducer, injectors and gas filter. The sets have been completed so as to ensure optimal operation of the system in all conditions.





## DIESEL DUAL FUEL

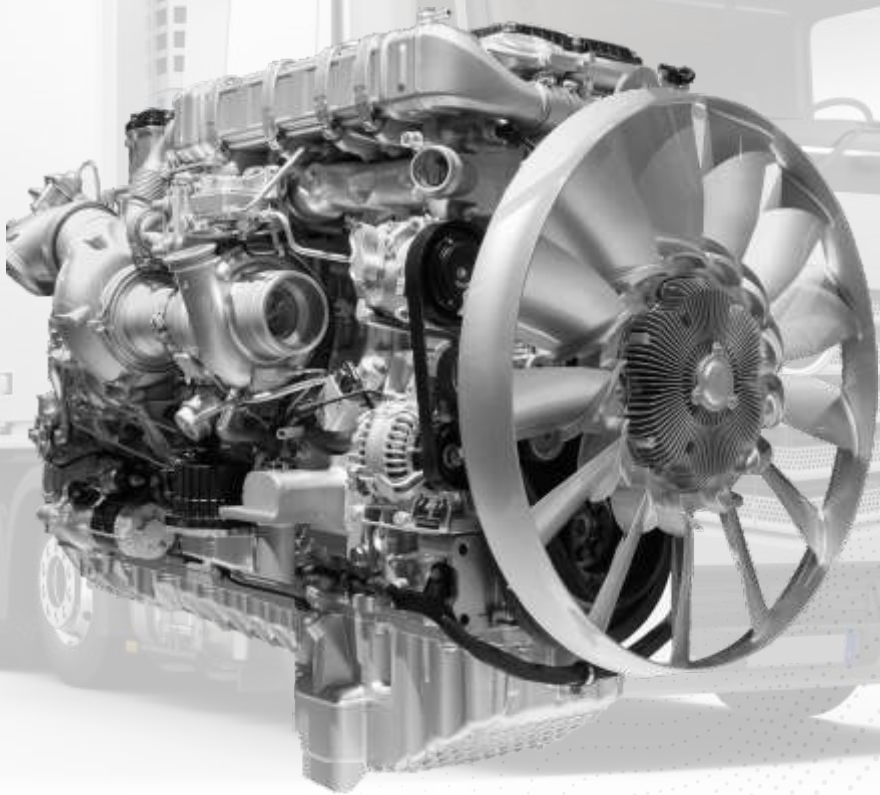

scalmax  
advanced autogas technology

# DIESEL DUAL FUEL SYSTEMS

## Scalmax SM014 Titanium

The **SM014 Titanium** controller is the first Polish diesel gas controller equipped with a patented innovative auto-adaptation system. The first installed systems have proven themselves in real conditions, driving over 900,000 kilometers. km without adversely affecting the engine. After many years of improvement and software optimization, the created controller is a comprehensive solution for diesel gas control. Due to the small share in the price of the entire installation, our diesel controllers are made only in the premium version without unnecessary savings.



### DSP Digital Signal Processor

DSP Digital Signal Processor available in the version designed for car electronics with high resistance to environmental conditions (-40° to +125° [C]).



### DFC DDF Dual Fuel Calibration – smart calibration

It is a unique Scalmax technology which allows installation of dual fuel system in cars without engine test beds or load tests.



### CRE Common Rail Emulator

Common rail pressure sensor analogue emulator allows installing the system in engines equipped with this system.

ECE R67, R110, R10 approval

**sold in a package with accessories and a wiring harness**



# DIESEL DUAL FUEL SYSTEMS

## Scalmax SMO48 Prime

**Sm048 Prime** is the latest Dual Fuel controller. It combines the best features of previous versions as it allows operation of simple vehicles with a mechanical pump, as well as the newest truck Euro 6 designs. It is the first diesel-gas controller with built-in CAN interface. Its analogue emulator has an increased precision. It can also cooperate with GPS module and can be updated via GPRS. To provide assemblers with comfort, a longer 6-meter bundle divided into 2 sectors connected by hermetic joint has been applied.



### DSP Digital Signal Processor

DSP Digital Signal processor available in the version intended for car electronics with increased resistance to environmental conditions (-40° to +125° [C]).



### DFC DDF Dual Fuel Calibration – smart calibration

It is a unique Scalmax technology which allows installation of dual fuel system in cars without engine test beds or load tests.



### CRE Common Rail Emulator

Common rail pressure sensor analogue emulator allows installing the system in engines equipped with this system.



### 3x ASE II Analog Signal Emulator

Analogue Signal Emulator allows application of Scalmax Diesel system in trucks equipped with this type of sensors (Common Rail, AFM, TPS).



### 2x DSE Digital Signal Emulator

Digital Emulator with two channels allows application of Scalmax Diesel system in trucks equipped with this type of sensor.



### RELAY External Relay Control

External relay control. In dual fuel system frequently used in ADR trucks for automatic system disconnection from the battery.



### OBD connection to CAN bus in Premium version\*

Diagnostic parameters readout and error deleting  
\*at present option available for cars and Volvo trucks

ECE R67, R110, R10 approval

**sold in a package with accessories and a wiring harness**





# DIESEL DUAL FUEL



**TRUCKS**



**BUSES**



**VEHICLES  
AND MUNICIPAL  
MACHINES**



**AGRICULTURAL  
VEHICLES**



**CONSTRUCTION  
VEHICLES**



**POWER  
GENERATORS**

# DIESEL DUAL FUEL

## Diesel Dual Fuel + Telemetry.

---

Diesel Dual Fuel injection system + Telemetry. To meet the expectations of installers and vehicle owners, an integrated data exchange system between the vehicle computer and the DDF gas controller was developed. Thanks to Telemetry, the vehicle owner can see the parameters of his vehicle and the effects of the gas system on an ongoing basis. It can perform reports, analyzes and receive automatic notifications, among others about the place of refueling LPG/CNG/LNG.

- remote monitoring of DDF systems
- remote change of DDF system settings
- engine monitoring
- full control of vehicle parameters, vehicle location, speed, entry from the planned route, refueling point, distance traveled, etc.
- safety for driver and cargo
- control of diesel and LPG / CNG / LNG fuel consumption

**GPS/GPRS**  
**OBD/CAN**



# CNG/LNG Reducer with Innovative Electric Heating System - Professional Solution for Engines up to 300 kW.

The new generation CNG/LNG reducer is a technologically advanced device, designed for the most demanding applications in gas installations of vehicles fueled by compressed natural gas (CNG/LNG). Thanks to precision CNC machining and an innovative electric heating system, the reducer ensures reliable operation even in extreme weather conditions, eliminating the need for lengthy engine warm-up.

## Key features:

Electric heating of the reducer body - The innovative heating system effectively stabilizes the operating temperature of the reducer from the first seconds of operation, increasing user comfort and shortening the time of switching to CNG/LNG supply.

- Power up to 300 kW - The design optimized for efficiency enables trouble-free operation of drive units with a power of up to 300 kilowatts. Integrated solenoid valve - Optional integration with a solenoid valve simplifies installation, improves system reliability and increases the safety of the system installation operation.
- Heating fluid circulation - Two Ø8 mm water ports ensure optimal circulation of the coolant, which supports thermal stabilization.
- Working pressure:  
Input: up to 200 bar  
Output: adjustable, up to 3.5 bar
- Precise adjustment using a 4 mm Allen key allows for precise adjustment of the output pressure to the requirements of a specific engine.
- CNC technology - All metal parts are manufactured with the highest precision using CNC technology, which guarantees a perfect fit of components, high mechanical strength and tightness of the system.
- Temperature measurement - Integrated M5 thread for a temperature sensor allows for precise monitoring of operating conditions in real time.
- Gas nozzles Ø12 mm - Solid connections guaranteeing safe and efficient gas flow under heavy loads.



# scalmax

advanced autogas technology



SCALMAX Paweł Poptawski  
Polska 2 st, 15-624 Białystok  
POLAND

DDF@scalmx.pl  
trade@scalmx.pl

+48 793 792 485  
+48 85 307 08 31



[www.scalmx.pl](http://www.scalmx.pl)

ISO 9001:2015